

Safe use and operation of play inflatables, including bouncy castles

Introduction

This information sheet has been revised to reflect changes in the registration requirements for those who inspect play inflatables. Previously, these devices were to have been subject to inspection under the Amusement Devices Inspection Procedures Scheme (ADIPS). However, due to a delay in reaching agreement on suitable Service Quality Schedules for the inspection of these devices, it is not possible for duty holders to comply with the requirements of ADIPS at this time. Duty holders will still have to comply with their duties under Sections 2 – 6 of the Health and Safety at Work etc. Act 1974, as appropriate.

This information sheet is written to provide guidance for those involved with the design, manufacture, importation, supply, inspection and safe use of play inflatable devices. It lists possible hazards and outlines the precautions that need to be taken to avoid them. It covers inflatables used for bouncing and other purposes but not those used solely for protection. It does not cover waterborne inflatables used in swimming pools or other types not used by the public for entertainment purposes.

This guidance has been prepared in consultation with the members of the Fairgrounds Joint Advisory Committee, the Inflatable Play Manufacturers' Association, the Association of Play Industries, the British Inflatable Hirers Association, the Made Up Textiles Association, the Association of Inflatables Manufacturers, Operators, Designers and Suppliers, and other interested parties.

Definitions

Inflatable devices - Fairground equipment consisting of air-filled structures designed to allow users to bounce, slide or climb on them. They are made from flexible fabric, kept inflated by one or more blowers and rely on air pressure to maintain their shape .

Controller - The person, organisation or hirer (those who hire to others) having the overall control, including responsibility for maintenance, of the inflatable device.

Operator - The person over the age of 18 and appointed by the controller to be in charge of the operation of the inflatable at any time when it is intended to be available for public use.

Attendant - Any person over the age of 16 and appointed to work under the control and direction of an operator to assist in the operation of the inflatable device.

Safety critical parts – those parts where there is a real risk of failure leading to injury.

Recognised hazards

The following hazards have been known to occur:

- instability and blowing away in windy conditions;
- situations caused by loss of pressure as a result of

- failure of the fabric zips and seams;
- failure or loss of power to the blower;
- disconnection of the blower; or
- litter blocking the air intake and/or vents;

- falls from the structure;
- windows tearing or detaching;
- tripping (particularly over anchorages);
- injury to users caused by boisterous behaviour, overcrowding or not separating larger users from smaller ones;
- access to dangerous (parts of) machinery (e.g. inadequately protected, or unguarded, blower units);
- electrical hazards (e.g. shock or burns);
- inadequate means of escape in case of fire;
- lifting injuries caused by manual handling;
- injury to users caused by wearing inappropriate clothes and shoes;
- suffocation; and
- entrapment.

Duties of manufacturers

Manufacturers should ensure that they manufacture their products so that they are, so far as is reasonably practicable, safe in use. Inflatables should be manufactured in accordance with good manufacturing practice, using suitable quality materials and using a suitable design. Where there are relevant standards, these should be followed.

Design considerations

The designer or manufacturer needs to make sure that:

- there are no parts of the device or ancillary equipment accessible to users which will cause injury if contact is made with them, e.g. sharp exterior angles or edges;
- there are no significant trapping points between adjacent surfaces;
- for bouncy castles especially, the outside walls are high enough, strong enough and attached to the base to prevent users falling out, bouncing over or slipping through gaps in normal use or foreseeable misuse. As a general rule, the height of users using an inflatable should not exceed the height of the outside walls when the user stands on the bouncing surface. Walls of 1.8 m or higher (measured from the bouncing surface) are sufficient for users of any height;
- the number and the maximum size of users that the structure can safely contain at any one time is specified in the operations manual; and
- the deflation time is sufficient to allow the structure to be safely evacuated - this can be considerably lengthened by using a non-return valve or flap fitted to the blower or by fitting the blow-tube to the lowest part of the structure, as near as possible to the ground.

Anchorage

Structures should be provided with an adequate anchorage and/or ballast system. Any anchorage points should be suitably protected where appropriate. The size, number and strength of anchorage points should be adequate for the structure and take into account likely wind loading. The designer/manufacturer should carry out research to determine maximum wind speeds and specify the type of anchorage for each inflatable device to be safely used. This information should be kept available.

Access/egress

On any open side the maximum fall-off height should be no greater than 750 mm. Any hard landing surface, including grass, should be covered by soft landing material such as dense gym mats or equivalent material of at least 25 mm thickness but not more than 125 mm, extending for a distance of at least 1.2 m from the open side. Safety mats used indoors should be fire-resistant. When it is necessary to have anchorage points near to an entrance/exit, they should be connected in such a way as to minimise the danger of tripping, abrasion or other injuries.

Blowers

These should be suitably guarded at inlet and outlet (IP2X is satisfactory - see BS EN 60529). The inflatable structure should be designed so that the user cannot contact the blower unit. This may be achieved by ensuring the length of any inflation tube is at least 1.2 m when positioned on a walled side and 2.5 m on any open side. Blowers should not be sited internally unless they are in a part of the structure not used for playing and out of possible contact by the user. The fitting of an auditory or visual alarm to the blower unit should be considered to alert the operator of any failure in the fan's electric (or other) power supply.

Special considerations for totally enclosed structures

In totally enclosed structures the following additional requirements should be satisfied:

- signs should indicate exits, meeting the requirements of the Health and Safety (Safety Signs and Signals) Regulations 1996;
- an independent support system should be provided for any lighting, emergency lighting and loudspeaker systems;
- the electrical installation should, as a minimum, conform with the requirements of BS 7671;
- structures designed to accommodate more than 15 people should have more than one exit so that the inflatable can be evacuated quickly. Deflation time should be sufficient to allow the structure to be safely evacuated;
- emergency lights should be provided as a back up if a lighting system is installed. The discharge period for the lighting following supply failure should be sufficient to allow for the complete

evacuation of the structure. Systems should be fully charged prior to use of the inflatable. Lighting should be proved each day before a totally enclosed inflatable is put into use;

- electrical cables should be kept adequately secured away from any users or spectators; and
- electrical equipment exposed to the weather should be protected to BS EN 60529 or be located inside a weatherproof hut or cabin.

Materials

Flexible fabrics used in the construction of inflatables need to be of adequate tear and burst strength and have sufficient air retention to enable the structure, when pressurised to the level specified in the operations manual, to maintain its shape and prevent the structure from distorting under load. In particular:

- fabrics should be flame-resistant (see 'Further reading') and meet current fire safety standards;
- adhesives should provide a bond of not less than the equivalent strength to the fabric being bonded;
- threads used for sewing should be strong enough for the purpose;
- zips should be able to withstand the air pressures generated in the structure. Where they are used for emergency exits they need to be reliable, easy to use and operable from both sides;
- netting should not create additional risks to users;
- where windows or other similar openings are provided, the materials used, and the method of attachment to the rest of the structure, shall be of adequate strength to withstand impact from users; and
- toxic decorative finishes must not be used in areas accessible to users.

Buying and selling inflatable devices

Inflatable devices should not be bought or sold unless the following documentation is available:

- for devices manufactured after January 5th 2004, a declaration by the manufacturer that the inflatable has been manufactured to an appropriate design and in an appropriate manner (this may be achieved by a declaration of conformity to an appropriate European Standard); and
 - ❖ an operating manual, which includes:
 - ❖ any limits on numbers of users;
 - ❖ details of weather conditions in which the inflatable should not be used;
 - ❖ details of how to set up the inflatable;
 - ❖ anchorage arrangements;
 - ❖ details of any routine maintenance or inspection required;
 - ❖ specification of mats used to protect entrance and exit points; and
 - ❖ appropriate daily checks.

The operating manual can also be a good place to keep records of maintenance, modifications, daily checks and annual inspections.

Where a device has been manufactured in Great Britain, the duty to provide the information referred to earlier falls to the manufacturer. For a second-hand or hired device, the duty falls on the supplier. However, in the case of an imported ride, whether new or second-hand, the duties fall to the supplier.

The controller of a newly acquired second-hand device should ensure that the operations manual is present and complete. The records of maintenance, modifications and inspections should accompany any second hand device.

Duties of controllers or operators

Owners or operators of devices will need to carry out a risk assessment of their activities to determine the control measures to avoid risk or reduce risk to acceptable levels. This will be relatively easy to do using the manufacturer's information and instructions for safe operation. This is a requirement of the Management of Health and Safety at Work Regulations 1999.

The operations manual should be made readily available. This should not mean that it is kept next to the equipment or that it is written on paper. Computer storage systems may be acceptable for some information, but only if it can be accessed easily and a hard copy produced if required.

Inspection, maintenance and modification

The Provision of Work Equipment Regulations 1998 (PUWER) require inflatable devices to be inspected at suitable intervals to ensure that safe conditions are maintained, and that any deterioration in the device is detected and remedial action taken in good time. (See following paragraphs on annual inspections and daily checks.)

Annual inspection

Each inflatable should be thoroughly inspected at least once in every 12 months. This procedure needs to be carried out by a competent person. The Annual inspection needs to include checks of the following:

- previous inspection reports and certificates where appropriate;
- provision of a blower unit as specified by the manufacturer, or one that at least provides sufficient pressure to allow the inflatable to be used safely, suitably guarded at the air inlet and outlet;
- condition of blower impeller and fan casing where practicable to inspect;
- condition of accessible blower electrical wiring;
- condition of all electrical installations;
- anchorage system for wear, rips or chafing;

- type and number etc of ground anchors or ballast for conformity with design specification;
- structure for wear or rips in the fabric;
- walls and towers (when fitted) are firm and upright;
- pressure is sufficient in the bouncing area and at the step/front apron to give a reliable and firm footing;
- internal ties for wear and tear, particularly at loose or exposed ends;
- bed seams, wall-to-bed seams and wall-to-tower connections;
- identification of the device; and
- if used on a fixed site, the location.

Inspection of some of these features may need to be done inside the device. The above list is not exhaustive and the manufacturer may specify additional items. Annual inspection needs to include any part of the inflatable and its ancillary equipment that may affect the safe operation of the device.

Daily checks

Checks should be carried out before the first use on any day using advice provided by the manufacturer in the operations manual. These should include checking that:

- the site remains suitable, with crowd control measures in place if appropriate;
- anchorages are intact, protected where necessary, and ropes not worn or chafed;
- anchor system secures the inflatable device to the ground;
- there are no significant holes or rips in the fabric or seams;
- the correct blower specified for the device is being used and the air pressure is sufficient to give a reliable and firm footing;
- there are no exposed electrical contacts, there is no wear on electric cables, and plugs, sockets and switches are not damaged;
- if an internal combustion engine is used, that the fuel cap is placed firmly on the fuel tank and any reserve fuel tank is suitable and remains in a safe position;
- bolts and screws of the blower are properly secured and that robust guards are secured over the air inlet and outlet;
- the blower/inflation tube connection is in good condition and is firmly fixed to the blower; and
- the blower is positioned correctly, adequately protected or guarded and is not causing a tripping hazard.

The public should not use the inflatable until any defects identified in the daily check have been rectified.

Maintenance

The inflatable needs to be properly maintained - the instructions contained in the operations manual should be followed. Where such instructions are not available, the controller should specify the procedures required, in conjunction with advice received from a competent person, the supplier or manufacturer. Details of all maintenance work on the device should be recorded in the operations manual.

Modification

Safety-critical modifications are those where failure of the modified component or system would lead to a significant risk of injury to public or employees. They could include changes in the operating parameters of a device, such as changing the height restriction of users. If in doubt, take advice from a competent person.

Where a safety-critical modification is made (including the replacement of a component which departs from the original design specification), the modification needs to be carefully considered. The conclusions and justifications should be recorded in the operations manual before the change is made. If a device is CE marked, alteration may invalidate the declaration of conformity and the device may need to be reassessed against the relevant standard.

Safe operation

It is essential for the safe operation of a device that the manufacturer's instructions regarding the use of anchorage points should be followed. The device should be secured to the ground with ground stakes, where the ground is suitable. Some equally effective method can be used on hard standing, e.g. attaching the anchor ropes to fittings already in the ground, or to sandbags or other weights, if these are capable of taking the load.

Inflatables can be tied to a vehicle or other movable machinery, providing the vehicle or machinery is immobilised and under the control of the operator.

Inflatables should not be used when the wind or gusts are in excess of the maximum safe wind speed specified by the manufacturer. The industry recommends a maximum wind speed of Force 5 on the Beaufort scale of 30-38 kph (19-24 mph). Force 5 is a fresh breeze when small trees in leaf begin to sway, whereas Force 6 is a strong breeze when large branches are in motion, whistling can be heard in telephone lines and umbrellas can only be handled with difficulty. Weather forecasts can be obtained from the Meteorological Office.

The controller or operator should ensure that the inflatable device is sited well away from possible hazards such as overhead power lines or other obstacles with hazardous projections (e.g. fences). If the ground surface is abrasive, oily or dirty, a ground sheet should be used to prevent wear and tear of the base material.

The controller should determine the minimum number of attendants needed to operate the device safely, and ensure that at least these numbers of attendants are on duty when the device is in operation. In deciding how many attendants are required, the controller needs to consider matters such as the number of people using the device, the age of the users and the type of environment in which the inflatable is being used. Attendants should be aged 16 or over and the operator should be 18 or over.

If the risk assessment carried out by the controller shows that control measures are required to handle large crowds in the immediate vicinity of the inflatable, then crowd control barriers (see Figure 1) should be provided by the controller. Barriers should have the minimum dimensions shown at Figure 1. They should be at least 1 m high and be capable of withstanding people leaning on them, or being pushed against them. Where the public does not have access to the sides or back of the inflatable or crowd pressures are not anticipated, then a lower standard is acceptable.

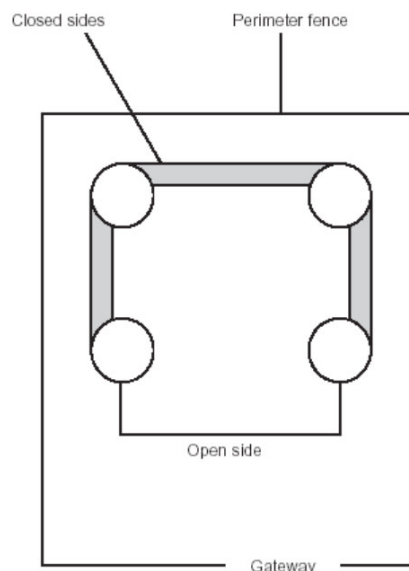

Figure 1

The perimeter fence should be 1.8 to 2.5 m from closed sides and 3.5 to 4.0 m from the open side. The gateway should be 1.0 m wide

The method of operation drawn up by the controller should ensure that users are admitted to the inflatable in a controlled and safe manner. In particular, the operator and attendants should carry out the following instructions.

- Ensure that users remove footwear (except socks) and any other hard, sharp or dangerous objects (such as buckles, pens, purses, badges etc). Glasses are best removed;
- Do not allow users to consume food or drink or chew gum on the device;
- Do not allow users to obstruct the entrance or exit of any inflatable device. Do not allow anyone to play on the step or front apron of a bouncy castle;
- Do not allow users to climb or hang on the walls;
- Do not allow users who do not conform to height restrictions to use the device;

- Keep the entrance/exit areas clear of onlookers so that the operator or attendant has a clear view and can ensure that users enter/exit safely;
- Keep users off the device when it is being inflated or deflated. Deflate the device when not in use.

The operator and attendants should watch the activity on the inflatable constantly. They should use a whistle or other signal and take action at the first sign of any misbehaviour. Somersaults and rough play should not be allowed.

It is the operator's responsibility to ensure that the equipment is not overloaded with users. Larger, more boisterous users should be separated from smaller ones. The number of users at any one time should be limited to allow each user enough room to play safely.

Training

The controller should ensure that all operators receive effective training in the working of the device including:

- the method of operating the device;
- safe methods of assembly/dismantling, where applicable; and
- how to make a daily check;

The controller should ensure that all operators and attendants receive effective training in the operation of the device including:

- safe entry/exit for users;
- safe anchoring of the inflatable;
- crowd control measures, and barriers;
- measures to be taken in the event of power failure; and
- procedures for reporting accidents, defects or breakdowns.

Accident reporting

Deal with any casualties first but report the event after the incident. Reportable accidents which cause injury, including acts of violence and certain dangerous occurrences, should be notified to the enforcing authority by the 'responsible person' (who is likely to be either the controller or operator). Further information is given in the HSE publication *A guide to the Reporting of Injuries, Diseases and Dangerous Occurrences Regulations 1995*. (See 'Further reading'.)

What to do if defects are found

If at any time a defect is found which could possibly lead to danger, the public should not be allowed to use the device until the cause has been identified and remedied. This may include checking all similar components. If there is any doubt about continued safety, the device should not be used until a competent person has confirmed that it is safe to do so. Keep records of all incidents and significant defects in the operations manual and the action taken, because they may be useful if you need to:

- give details to HSE, your trade association, insurers, the designer, manufacturer, importer or supplier;
- discuss the safety implications with a competent person; or
- provide a detailed accident history to a buyer.

Further reading

Fairgrounds and amusement parks: Guidance on safe practice HSG175 HSE Books 1997 ISBN 0 7176 1174 4

A guide to the Reporting of Injuries, Diseases and Dangerous Occurrences Regulations 1995 L73 (Second edition) HSE Books 1999 ISBN 0 7176 2431 5

RIDDOR reporting: What the Incident Contact Centre can do for you! Leaflet MISC310(rev1) HSE Books 2002.

BS EN 60204 -1: 1992 Safety of machinery. Electrical equipment of machines. Part 1. Specification for general requirements

BS EN 60529: 1992 Specification for degrees of protection provided by enclosures (IP Code)

BS 7671: 1992 Requirements for electrical installation. IEE Wiring Regulations (Sixteenth edition)

For further information on fire-resistant materials refer to BS EN ISO 6940: 1995, BS EN ISO 6941: 1995, and a new British Standard on play inflatables (in preparation).

While every effort has been made to ensure the accuracy of the references listed in this publication, their future availability cannot be guaranteed.

Further information

British Standards are available from BSI Customer Services, 389 Chiswick High Road, London W4 4AL Tel: 020 8996 9001 Fax: 020 8996 7001 Website: www.bsi-global.com

HSE priced and free publications are available by mail order from HSE Books, PO Box 1999, Sudbury, Suffolk CO10 2WA Tel: 01787 881165 Fax: 01787 313995 Website: www.hsebooks.co.uk (HSE priced publications are also available from bookshops.)

For information about health and safety ring HSE's InfoLine Tel: 08701 545500 Fax: 02920 859260 e-mail: hseinformation@natbrit.com or write to HSE Information Services, Caerphilly Business Park, Caerphilly CF83 3GG. You can also visit HSE's website: www.hse.gov.uk

This leaflet contains notes on good practice which are not compulsory but which you may find helpful in considering what you need to do.

This publication may be freely reproduced, except for advertising, endorsement or commercial purposes. The information is current best practise, to have been published by HSE before the end of 2003, but held back from publication due to the temporary moratorium on publications throughout HSE.